

UCS4

DESCRIPTION

Four-Port USB Charger

The UCS4 provides charging power for up to four USB-C sockets. Each port allows to charge and operate passenger equipment with up to 60W.

The power output of the UCS4 can be controlled and monitored by CMS controllers via the RS-485 interface.

This allows for detailed control of the electrical power provided in the cabin, both for controlling the power requirements in highly loaded aircraft networks and for centrally switching the power supplies of passenger areas.

The UCS4 integrated temperature and health monitoring allows for quick fault isolation.

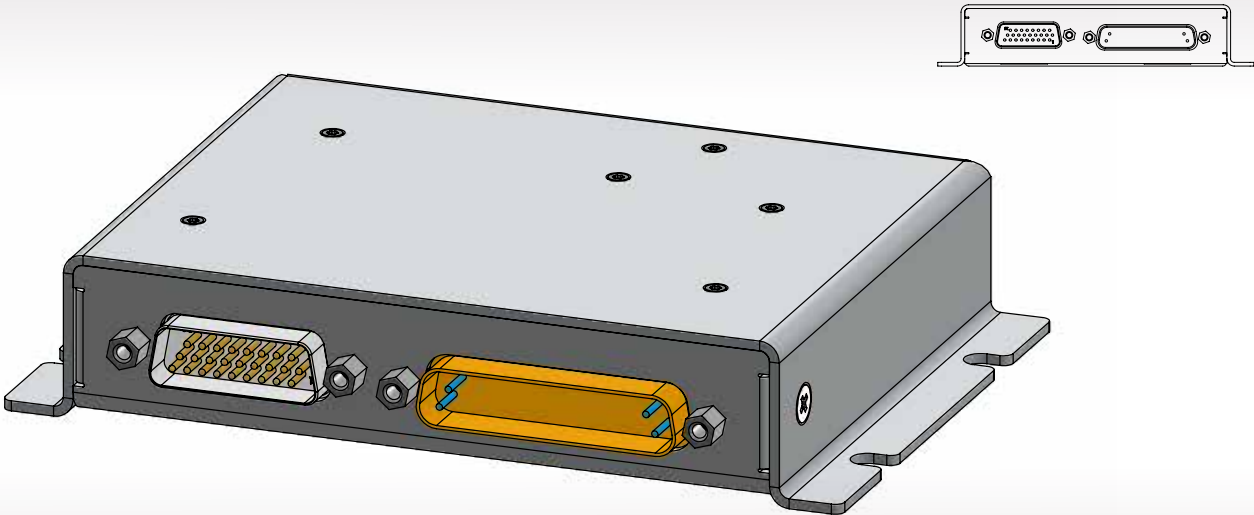

FEATURES

- compact size
- four channels with USB Power Delivery of up to 60W per channel.
- integrated load, temperature and health monitoring
- RS-485 interface for remote control by CMS.

OUTLINE DRAWING

dimensions are millimeter (mm)

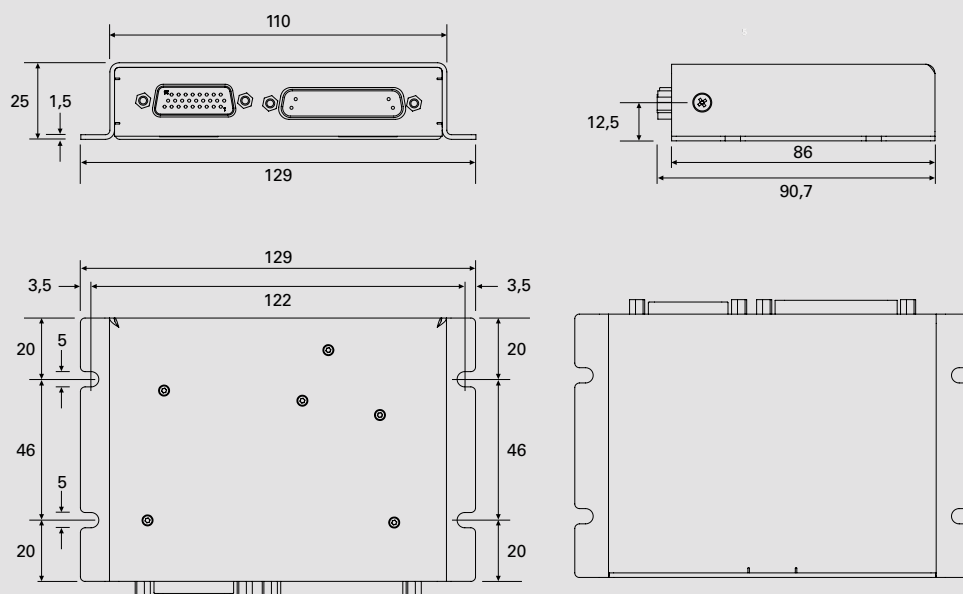

QUALIFICATION

- DO160

CONTACT

AlsterAero GmbH
 Heidenkampsweg 43
 20097 Hamburg
 Germany

phone : +49 (0) 40 2482712-0
fax : +49 (0) 40 2482712-22



email : info@alsteraero.com
web : www.alsteraero.com